



# 2<sup>nd</sup> Internship Report

*Vincent Davis – Facilities Team at SSBO*

# About Me

- Non-Traditional Student studying Mechanical Engineering & MATS at Oregon State.
- PCC is my 2<sup>nd</sup> MECOP Internship, 1<sup>st</sup> was at Intel in Aloha.
- I have a cat, Yin, who I raised from a kitten.
- I trained at Leung Martial Arts in Eugene for 3 years learning Tai Chi, Shaolin 5 Animal, & Wing Chun.
- I run a small eBay store where I sell retro games, collectibles, & 3D Prints.
- I build Warhammer models & play the game when I can.
- I make a great cheesecake.





Precision Castparts Corporation began as a small casting operation in Oregon and steadily expanded into aerospace and industrial markets. Over the decades, PCC became known for **investment castings, forged products, and fasteners** critical to jet engines, gas turbines, and industrial systems. Its growth strategy relied heavily on acquisitions, enabling it to dominate specialized markets like titanium production, airfoil castings, and aerostructures. Today, PCC operates as a subsidiary of Berkshire Hathaway, continuing to serve as a vital supplier to aerospace and energy industries.

**PCC**

## HISTORY:

- 1949** – Joseph Buford Cox, owner of Oregon Saw Chain, starts a small casting operation in Sellwood, Oregon.
  - 1952** – Ed Cooley begins running the investment casting operation.
  - 1953** – Precision Castparts Corporation officially incorporated on April 1 in Portland, Oregon.
  - 1956** – PCC formally incorporated as a public company.
  - 1960s–1970s** – Expansion into aerospace markets, producing castings for jet engines and industrial gas turbines.
  - 1995** – PCC reports \$436.4 million in sales, employing over 5,000 people.
  - Wyman-Gordon (forgings)
  - Special Metals (nickel alloys)
  - Other aerospace and industrial suppliers
  - 2012** – Acquisition of Titanium Metals Corporation (TIMET), making PCC a leader in titanium production.
  - 2014** – PCC reaches \$9.6 billion in revenue, with \$1.7 billion net income.
  - 2016** – Berkshire Hathaway acquires PCC for ~\$37 billion, one of Warren Buffett's largest deals.
  - 2020s** – PCC continues as a Berkshire Hathaway subsidiary, focusing on aerospace, energy, and industrial markets.
- 2012** – Acquisition of Titanium Metals Corporation (TIMET), making PCC a leader in titanium production.
- 2014** – PCC reaches \$9.6 billion in revenue, with \$1.7 billion net income.
- 2016** – Berkshire Hathaway acquires PCC for ~\$37 billion, one of Warren Buffett's largest deals.
- 2020s** – PCC continues as a Berkshire Hathaway subsidiary, focusing on aerospace, energy, and industrial markets.

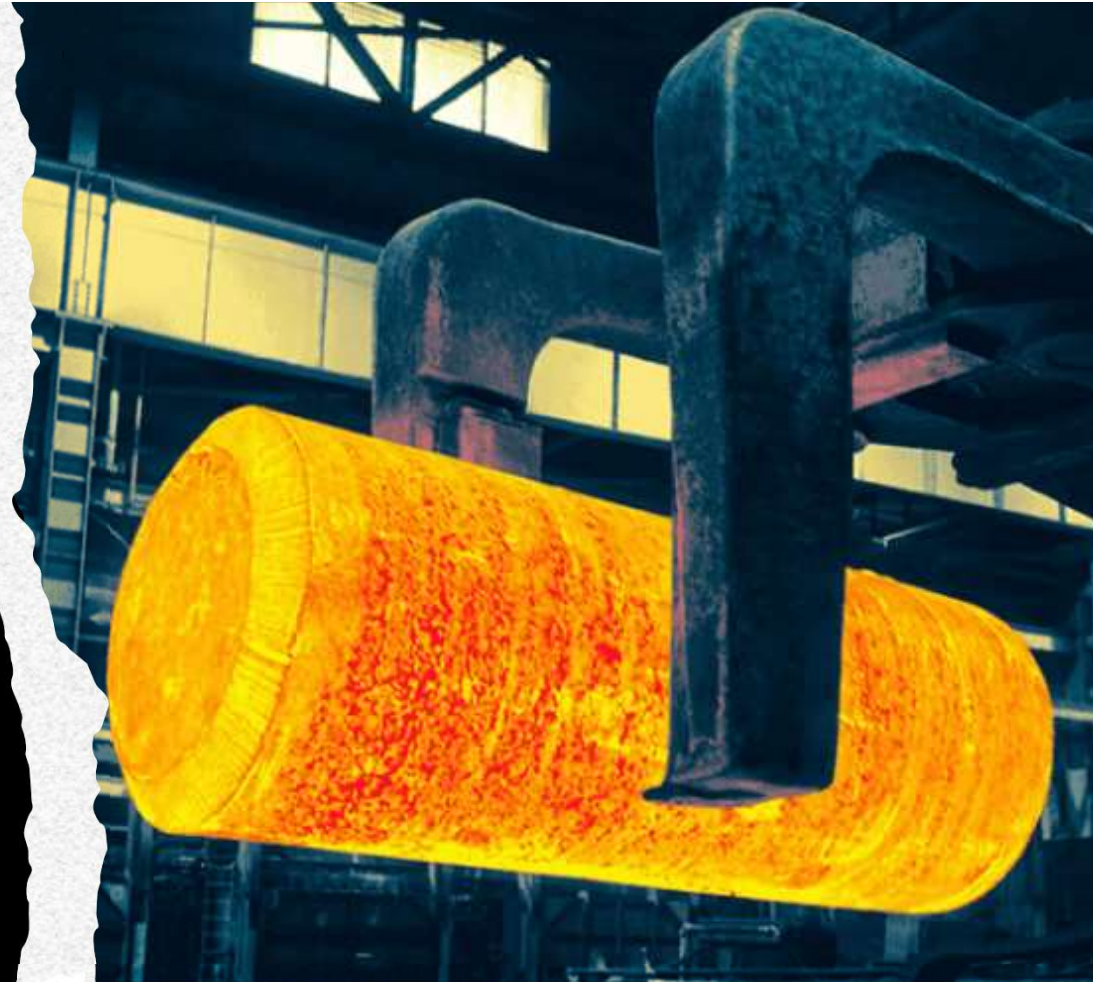

**PCC** Precision Castparts Corp

# Benefits of working at PCC



## Wages, Working Hours, & Benefits

- 40 Hours / Week @ \$26 / Hour
- Free Coffee!
- Health, Dental, & Vision Benefit Plans
- Quarterly bonus based on sales
- Free 175\$ safety toed boots
- Free Worktunes Bluetooth Headphones



**PCC** Precision Castparts Corp.

# PROJECTS



## PROJECT LIST:

1. Ingot Gripper Redesign
2. Mist Collectors for Targeting Department
3. FPI Retrofit
4. Leak Detection & Reporting
5. Wax Tank Safety Prop
6. Sandblasting Enclosure
7. Safety Signs
8. Sandblast Layout
9. 1<sup>st</sup> Inspection Hoist Upgrade
10. Swing Grind Booth Beam Change
11. Pot Carriage & Trunnion Cap Redesign
12. Air Casting Ventilation
13. Shotblast Platform Lift
14. Heat Treat Furnace Under-Guard
15. Burn-Off Turntable
16. VF8 Lead Holders (Hand Off from previous Intern)
17. Shotblast Nozzle (Hand Off from previous Intern)
18. Belt Sander Guard (Hand Off from previous Intern)
19. Hook Crossbar Modeling & Order

## REPORT STRUCTURE:

- + Brian Kemp (Plant Manager)
  - Jared Barnett (Facilities Manager)
    - David Jaramillo (Facilities Engineer)
- Vince Davis (Facilities Engineering Intern)

During this internship, I worked on the Facilities Engineering team under the direct supervision of Facilities Engineer David Jaramillo. My role as a Facilities Engineer was to investigate, develop, and plan out solutions in response to submitted RMEAs (Request for Manufacturing & Engineering Assistance). This required working with department stakeholders to ensure that needs were met, writing scope, performing job-walks with vendors, evaluating quotes, preparing Capital Request Justification forms, taking dimensions and modeling room layouts, parts, and assemblies, and other special projects.

## DEPARTMENTS ENGAGED:

- **FOUNDRY**
- **WAX**
- **CLEANING**
- **SAFETY**
- **FPI**



# Project Spotlight: SSB1 Sandblasting Enclosure

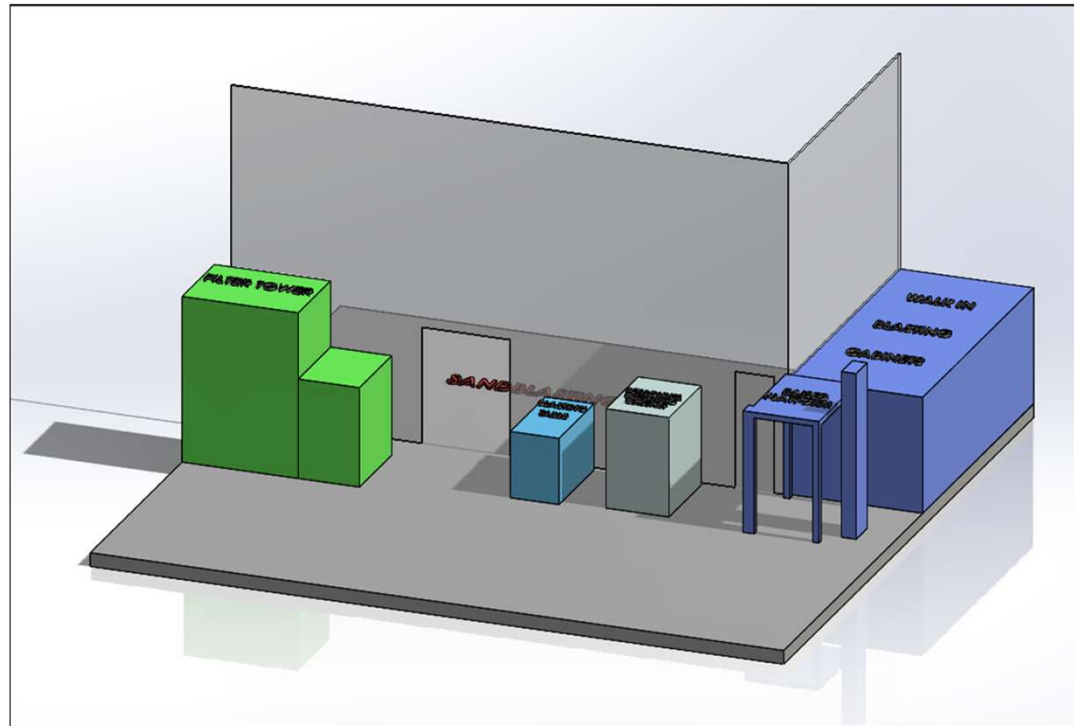

**PCC** Precision Castparts Corp.

Fig 1. SSB1 Sandblasting Area Concept Model

RMEA 25-037

## Scope:

Design an enclosure to prevent sandblasting particulate from escaping the area. The particulate is a health hazard in addition to increasing wear on machines in other departments.

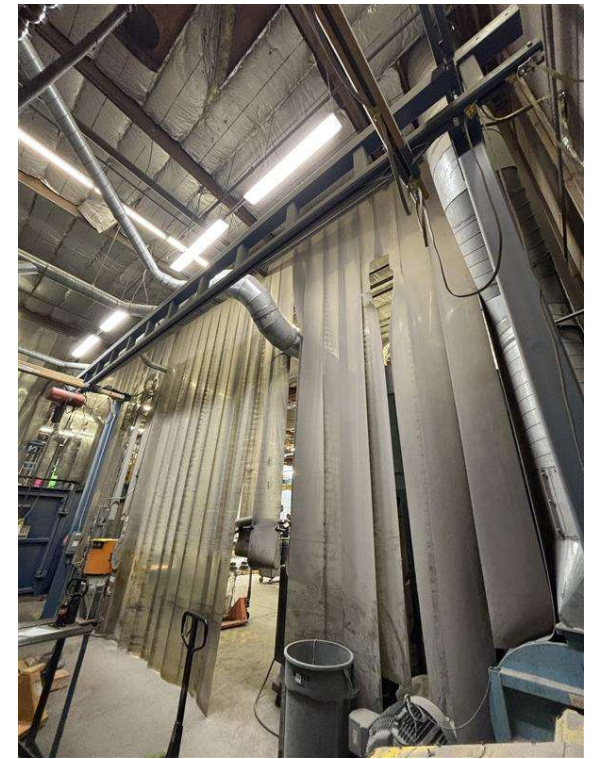

Fig 2. SSB1 Sandblasting Area and Strip Curtains



Fig 3. Industrial Curtain Examples

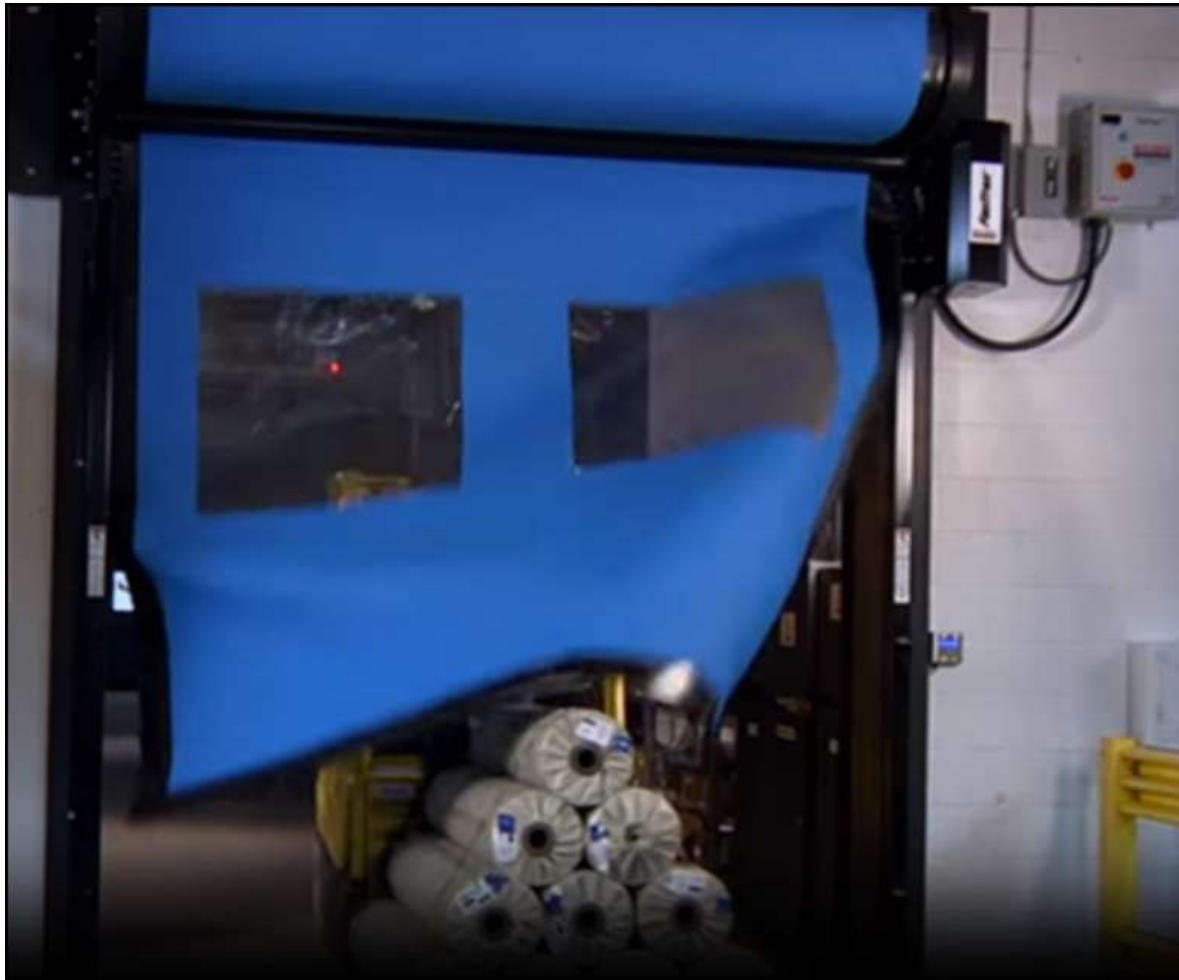
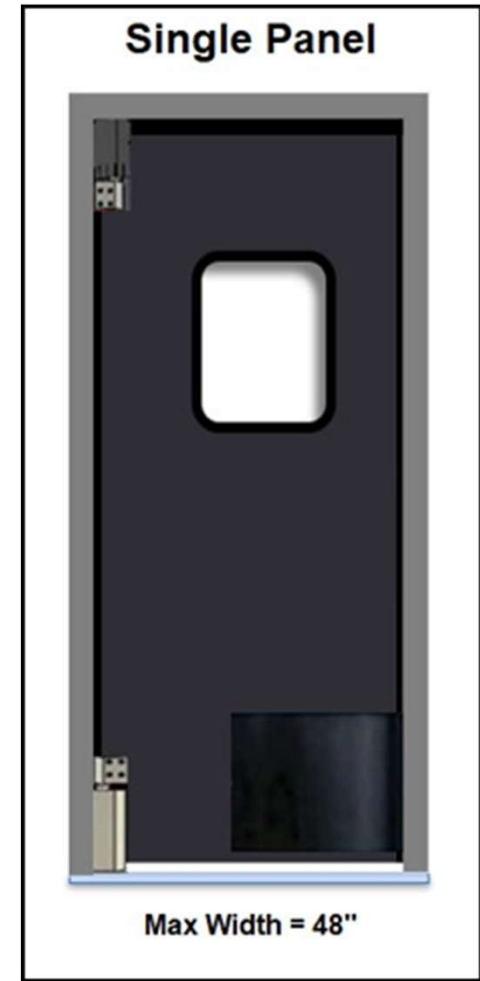

Fig 4. Door Concepts



# Business Impact:

Eliminating scrap risks and wear on machines outside the sandblasting zone saves capital by preventing premature breakdown, loss of good parts, and health issues that can be caused by exposure to particulate.

Cost Source	Cost
Installation	\$46,000
1 Instance of Dust Disease	\$73,311
1 Instance of Silicosis	\$314,689
Excess Wear & Loss of Good Parts	\$\$\$

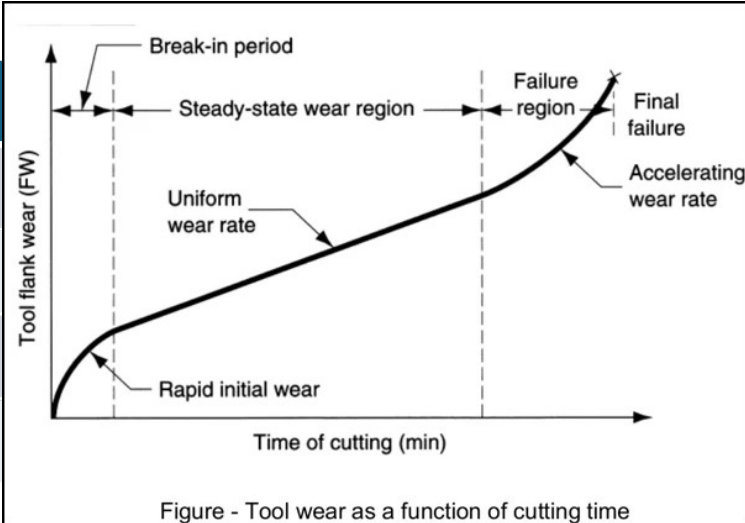

Figure - Tool wear as a function of cutting time

Also, with curtain walls it will be cheaper to modify the area in the future than with a rigid partition. This can save capital in the future should a change be made to the SSB1 sandblast area.

Current Status: Capital Allocated – To be Implemented in 1<sup>st</sup> Quarter of 2026

# Project Spotlight: Dip Tank Safety Prop

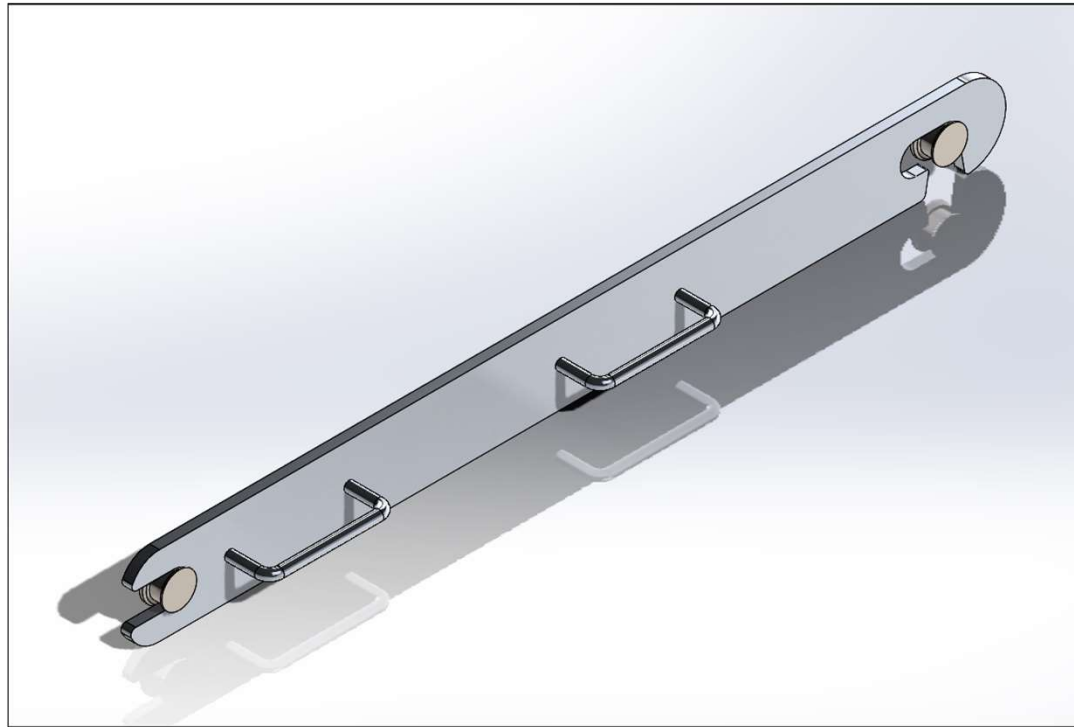

Fig 5. Safety Prop Concept Drawing

**Problem:** If the piston on the Wax Dip Tanks fails, the lid slams shut abruptly.

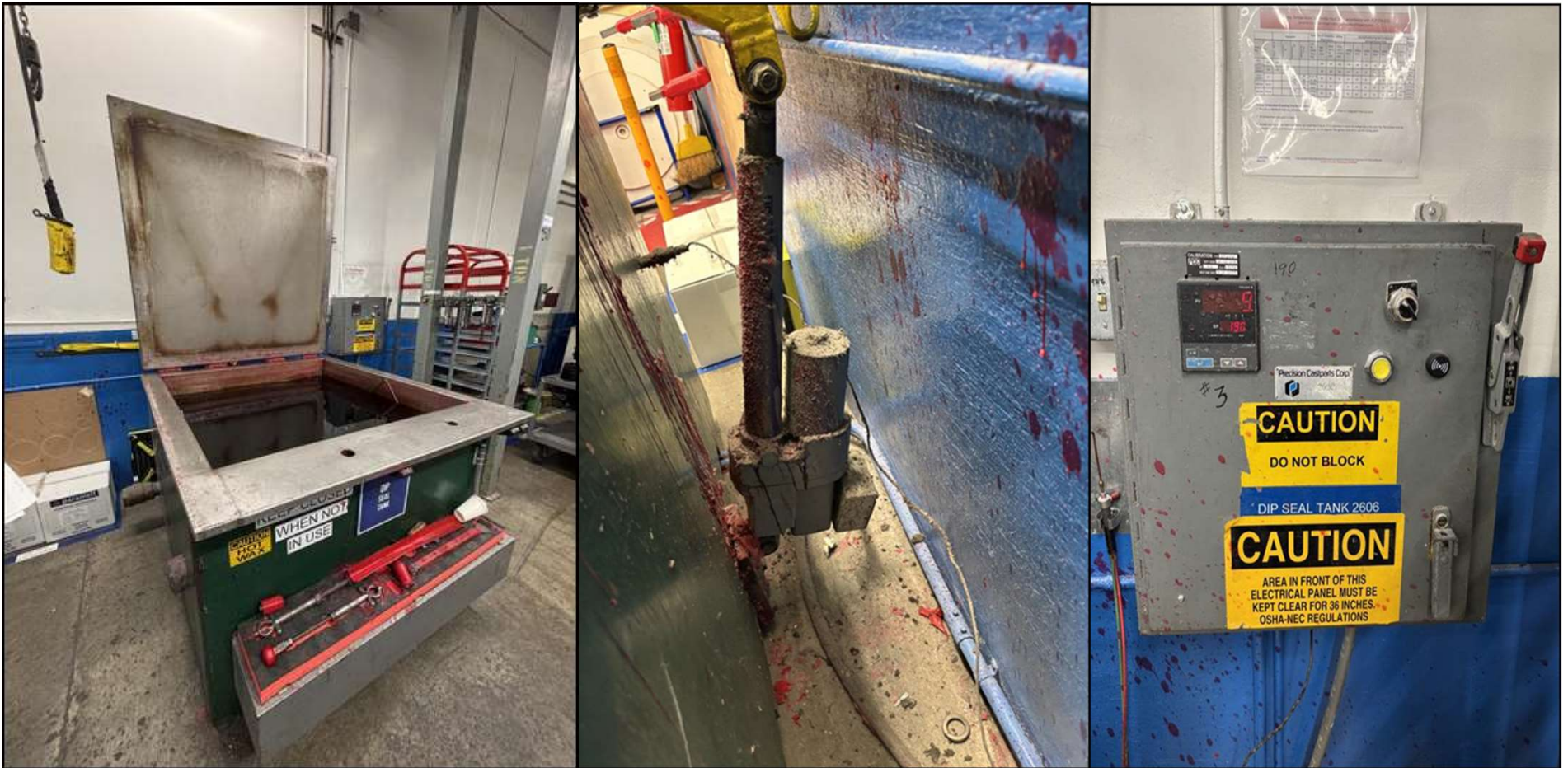
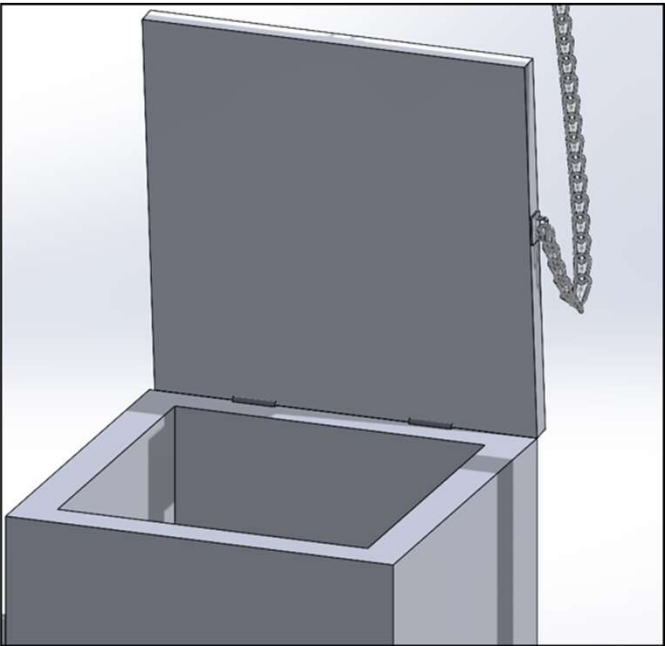
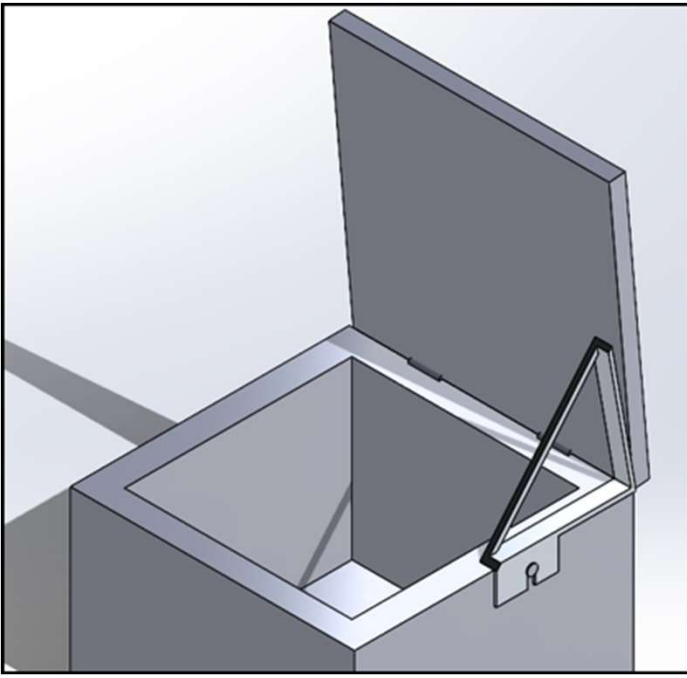
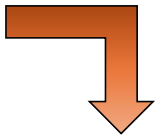

Fig 6. Wax Dip Tank & Lifting Piston



Safety Chain Concept



Safety Boot Concept

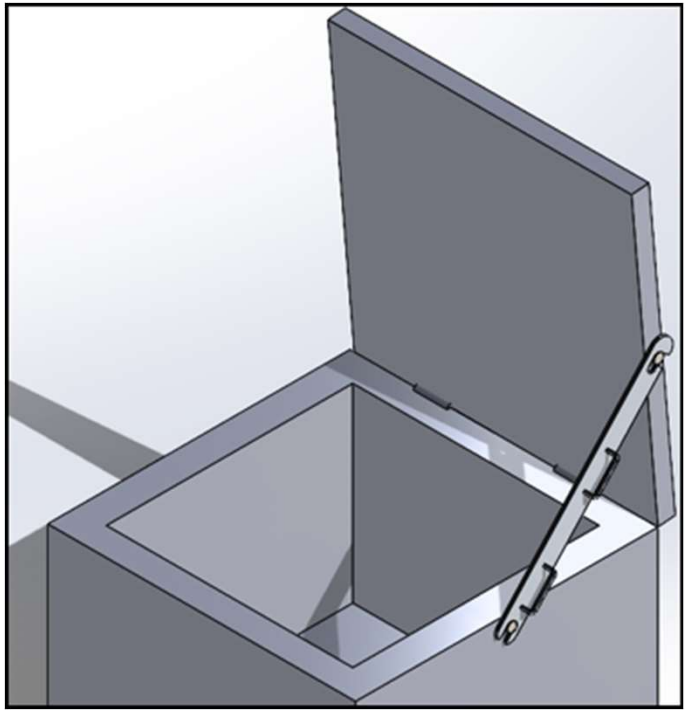
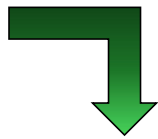

Safety Prop Concept

Fig 7. Safety Concept Iterations

## Business Impact:

This project was requested after a piston failure caused a dip tank lid to slam shut, fortunately without operator injury. Had the piston failed while the tank was being worked in, an operator could've been severely injured or worse.

Current Status: **Manufactured & Implemented**

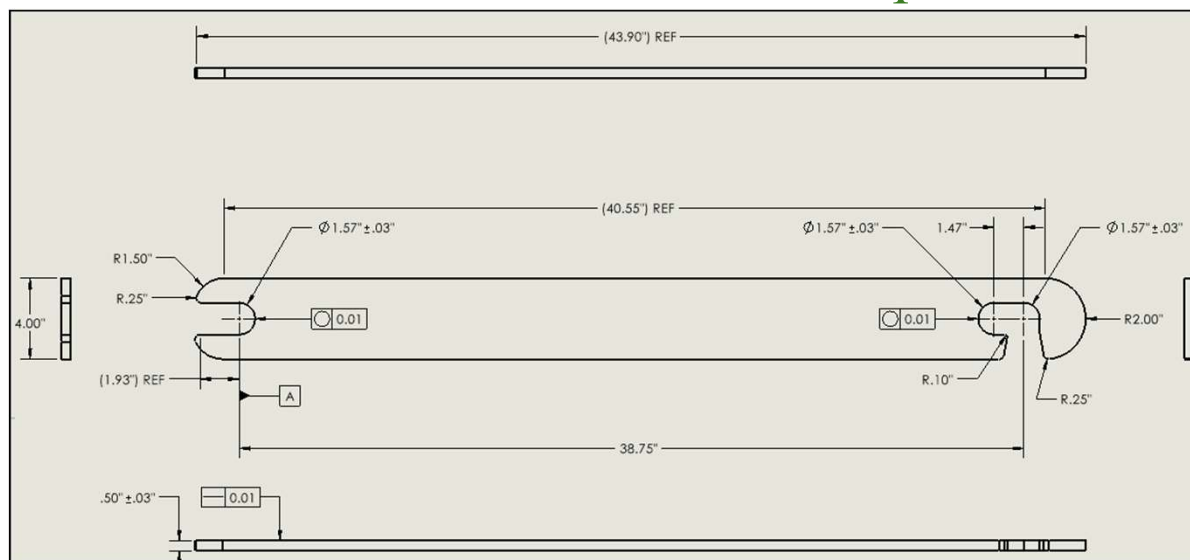

**PCC** Precision Castparts Corp.

Cost Source	Cost
Fabrication of Prop	875\$
Crushing Injury	140,706 \$
Fatality	1,000,000+ \$

# Project Spotlight: FPI Weld Booth Retrofit

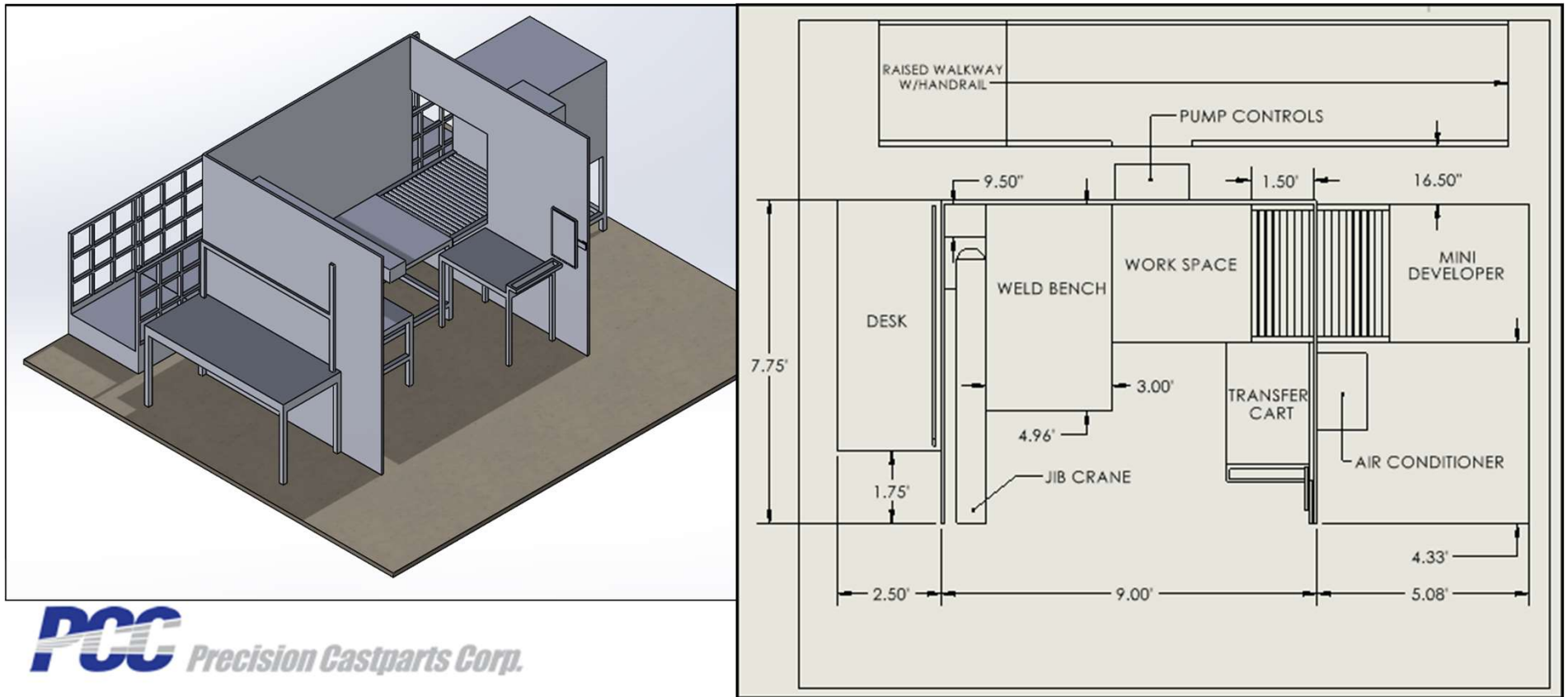
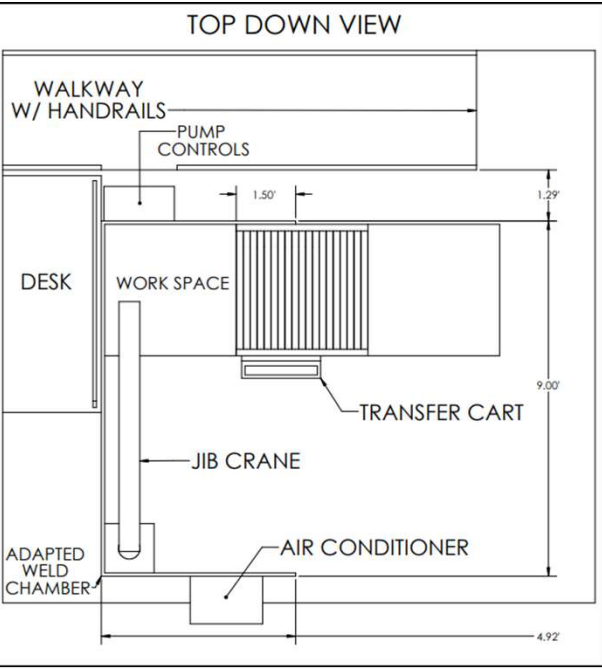
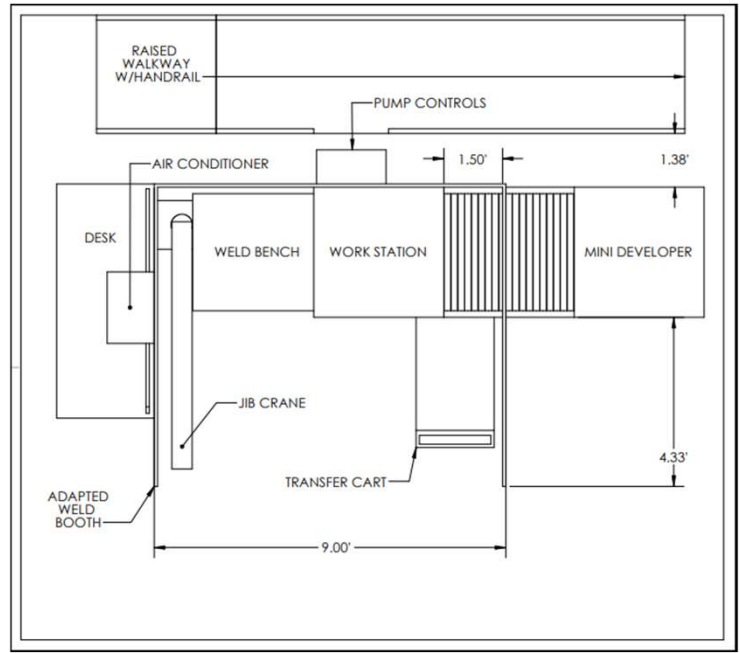
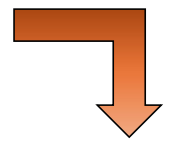

Fig 8. FPI Retrofit Model & Floorplan



Retrofit Layout Concept 1



Retrofit Layout Concept 2

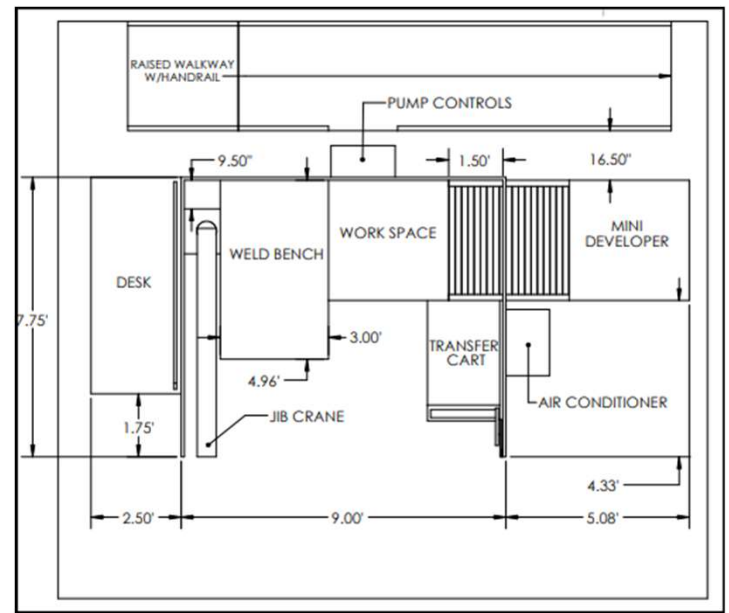
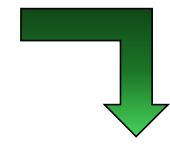

Retrofit Layout Concept 3

Fig 9. Retrofit Iterations

## Business Impact:

This project was a timely endeavor. My mentor David was in the process of having the weld booths removed and saw an opportunity to utilize one of them to improve the quality of life for FPI operators. This improvement will reduce turnover in FPI by making the inspection process more comfortable / ergonomic.

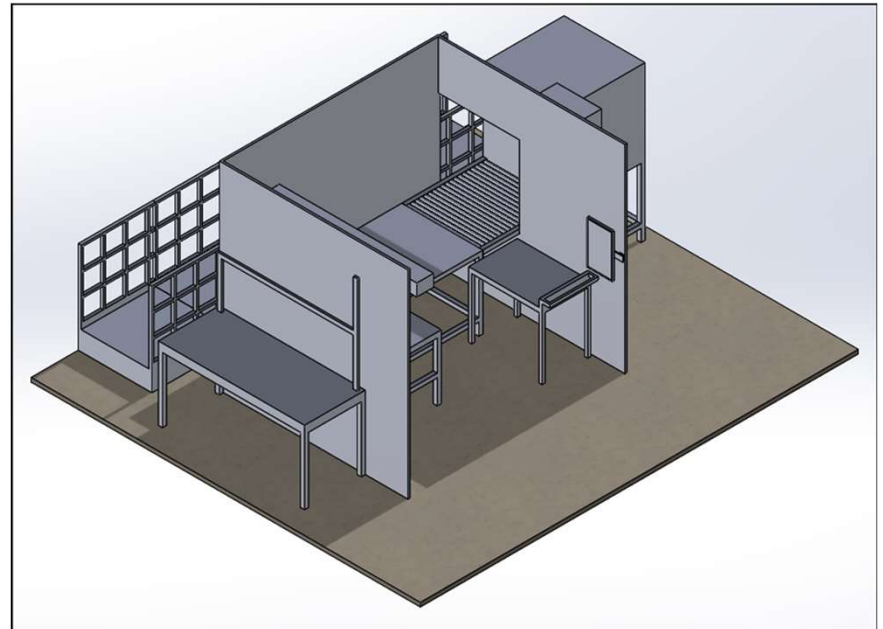



# KEY TAKEAWAYS & LEARNING

## Skills & Learning:

- SolidWorks / CAD
- Professional Communication
- 3D Printing / Scanning
- Everything takes longer and is more expensive than you think.
- Presentation & PowerPoint

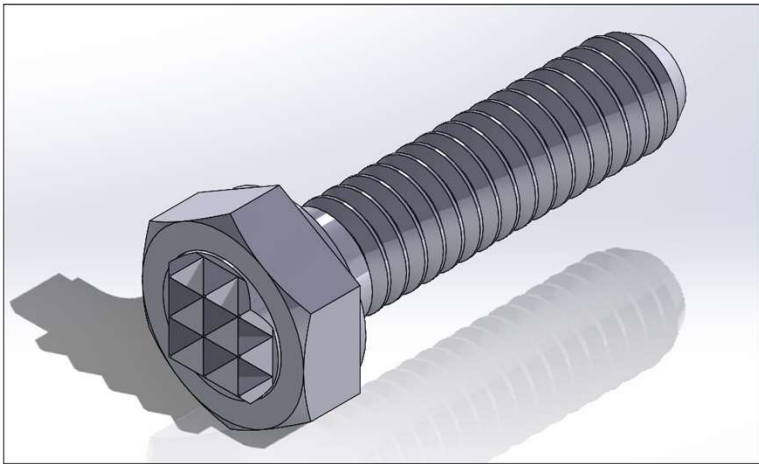

## Notable Courses Useful to this Internship

- ME 316, Mechanics of Materials provided a solid foundation to comprehend the stress & material strength which I used to perform stress analysis.
- MATS 321, Introductory Materials Science gave me a great background for comprehending defects / deformation.
- WR 327 H, Technical Writing gave me a lot of practice in communicating technical detail which was a huge boon since much of my work required working with other departments, contractors, & vendors.



“We insist on quality and dependability; Not just in the materials and products we make, but in the people we recruit.”

**-Mark Donegan, PCC CEO**

